

**Philips Domestic Appliances and Personal Care**

# Service Manual

**TECHNICAL DATA**

Input voltage	: 230 V - 50 Hz
Input consumption	: approx. 1960W
Fuse	: 16 A
UVA source	: 4x HPA Flexpower 400-600
Ballast	: 4x 400 W : 1x 100 W
Starter	: integrated soft start system
Timer	: digital 30 mins
Cooling	: 1x fan floor part : 2x fan tanning part
Radiation area	: 190 x 70 cm
Output (min) UVX-36 meter	: 3.6 mW/cm <sup>2</sup> at 65 cm
Protecting goggles	: 2x HB072 - 4822 690 80147
Safety	: CENELEC insulation class 2 : UV type 3
Weight	: approx. 37 kg

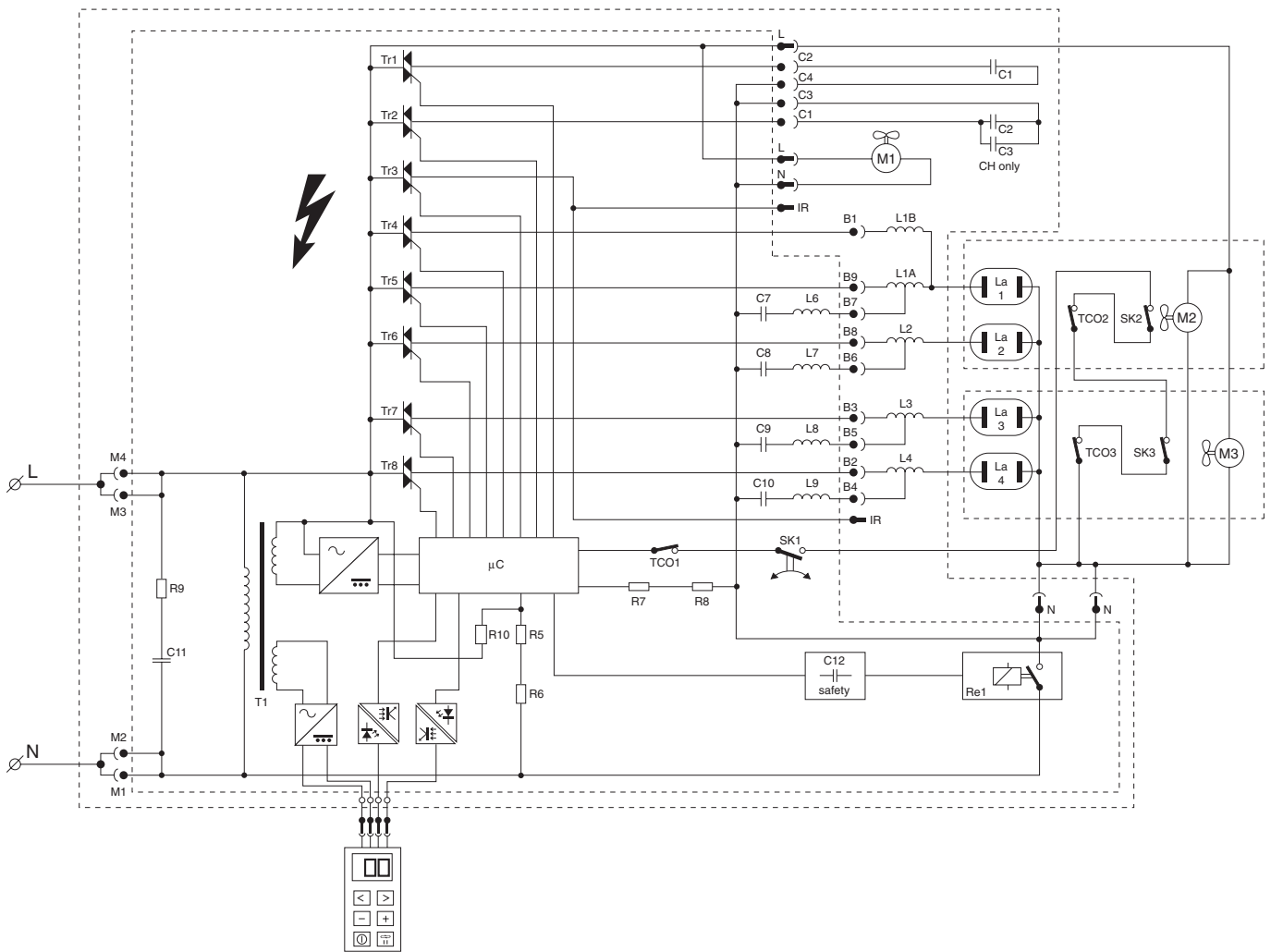

## TECHNICAL INFORMATION

Tanning appliance HB 953 is equipped with a universal power PCB.

This means that the specific characteristics of the appliance have to be programmed in a microcontroller to determine the way in which various components are activated.

When the mains plug is inserted into the wall socket, the display of the remote control will show all functions available to the user.

Including the various combinations, these functions are:

- time setting
- ☼ ☼ ☼ full body tanning
- ☼ ☼ ☼ full body + facial tanning
- ☼ ☼ ☼ half body + facial tanning
- ☼ ☼ ☼ half body tanning
- UV working hours

The UV lamps may produce a humming sound just after start-up. This humming sound will stop as soon as the lamps burn properly, which is after about 20 seconds. At this point the light intensity clearly increases.

During the last minute of the session the beeper produces an intermittent signal to alert the user to the fact that a new session can be set.

After pressing the ☼ key, the display showing ☼ and □□, the UV working hours will be shown. After 750 operating hours, an L will automatically appear on the display to indicate that the HPA lamps need to be replaced or the tanning time must be slightly increased.

The clock speed of the  $\mu$ -controller is derived from the 50 Hz mains frequency.

This frequency is also used to control the 8 triacs that determine the switch-in point (soft start) of the  $\cos \varphi$  capacitors and the HPA lamps.

The fans are switched via the safety relay.

This relay is part of the (one fault condition) timer circuit.

If the control of the triacs is disturbed due to a fault in the  $\mu$ -controller, the UV lamps may not be switched off.

As the  $\mu$ -controller also generates a pulsating direct voltage to power the relay, the relay will be de-energised in case of a fault, thereby interrupting the lamp circuit.

Conversely, the appliance will not start if the switch contacts of the relay are closed at that moment (sticking contacts).

The remote control is galvanically isolated from the mains, with power supply and control taking place via a 4-core cable.

The remote control only functions as input/output terminal.

## HINTS FOR REPAIRS

### 1. FLOOR PART (item 47)

- Remove the props (item 43) in the grip.
- Remove the covers (item 32 and 44).  
The cover on the flex side can only be removed last.

### 2. REMOTE CONTROL (item 30)

- Detach the cord clamp at the back of the cord holder and pull the connector loose.

### 3. WHEEL (item 35)

- Remove the covers (item 32,44).
- Remove the locking plate and the nearest frame screw.
- Push the shaft out of its clamping.

### 4. STAND LOWER PART (item 27)

- Put the appliance in the lowest operating position (however, screw (A) must be visible) and tighten the ornamental screw (item 26)
- Remove the covers from the floor part.
- Detach the 8-core cable so that the cable can easily slide through the cable duct.
- Remove the shafts (B).
- Remove the 2 bearing bushes (item 28).
- Pull the 8-core cable out of the stand tube to the point where the clamped joint between the cable bushing and the protecting sleeve can be unlocked.
- Detach the 8-core cable by loosening the nut of the bushing a quarter turn.
- Now turn the stand and the radiation units through so far that the covers (item 14/16) rest on the floor.
- Remove screws (A) and separate the upper and lower part of the stand.

### 5. STAND UPPER PART (item 22)

- Loosen the lower part of the stand as described under .4.
- Hinge the radiation units outwards (the upper part of the stand rests on the floor).
- Remove the housing parts and detach the wire connections.
- The covers (item 14/16) can now be separated from the hinge part.

WHEN A HOUSING AND COVER ARE ASSEMBLED, SPECIAL ATTENTION SHOULD BE PAID TO THE POSITIONING OF THE UPPER BEARING BUSH (see exploded view).

### 6. HPA LAMP (item 6)

- Put the appliance in operating position.
- Remove the 6 screws from the lamp unit in question.
- Remove the cover (item 14 or 16).
- Remove 4 reflector clamps.
- Remove the reflector and take the lamp from the holder.

NB: When checking or replacing HPA lamps, pay attention to the following:

- HPA lamps only start burning when they have cooled down sufficiently.
- Never touch a lamp with your fingers. Clean the lamp with a cloth moistened with alcohol, if necessary.
- After assembly the glass filter should be free from finger prints and dust. Clean the glass filter with a cloth moistened with alcohol, if necessary.
- New HPA lamps may show colour differences. This is not a defect, but a characteristic phenomenon of lamps of this type. The discolourations disappear after a short period of use.
- Always use protecting goggles when looking in the direction of burning lamps.

### 7. GAS SPRING (item 17)

- Let the radiation part slowly rise from its transport position.
- Hinge the radiation units outwards and remove a decorative cap and spring fix at C.
- Now push the radiation part back into transport position.
- Use a plastic hammer to tap the pin at C outwards.

NB: CONTINUE TO EXERT PRESSURE ON THE STAND.

- Hinge the radiation units inwards again and raise the stand slowly by means of the handle.
- Now turn the stand and the radiation part through so far that the radiation units rest on the floor.
- The gas spring is now unloaded so that pin (D) can be easily removed.
- Assemble the new gas spring, the protecting bracket and cover and press the pin (D) back in place again.
- Lift the radiation part by its handle and check whether the gas spring with pin (E) is correctly supported in the fork of the hinged part.
- Press the hinged part against the spring pressure, moving the radiation part along at the same time until the whole unit is in horizontal position again.
- Continue to exert pressure and hinge the radiation units outwards.
- Assemble the pin at C.
- Put the appliance in operating position, and assemble the remaining clamps.

### 8. POWER PCB (item 33)

- Pull the mains plug out of the wall socket.
- Remove the cover (item 32, see under .1).
- Replace the power PCB and connect all connectors.
- Place the cover on the base. The display of the remote control will now show error code E06 or E05.
- This indicates that the power PCB still needs to be programmed (code A03) for use in the HB 953 according to the input in the table.

The following fault codes have been defined:

#### E01 - Safety circuit interrupted

This code will appear on the display for 5 seconds, while the beeper produces a loud beep. Check whether all fans work or whether any UV filter is missing, broken or damaged.

#### E02 - Safety relay does not work according to specification

Replace the power module (item 33).

#### E03 / Fault in microprocessor

E04 - Replace the power module (item 33).

#### E05 / Application code not programmed

E06 - This only occurs in case of a new power module supplied by Service. Program the application code, beginning at line 1, step 3.

0	1	2	3	4	5	6	7	8	9	10	11
1	Open Service Mode	E05 E06	Press	+ 1x	+ 1x	+ 1x	+ 1x	+ 1x	+ 1x	C00	
2	Set Application Code	2x	C02	1x	A00	3x	A03	1x	C02	2x	C00
3	Close Service Mode	1x	00 								

Item	Service code	Description	Item	Service code	Description
1	4222 062 95270	aut. cutout 100 °C	26	4222 062 95400	orn. screw
2	4222 062 95250	clamp + cap (set)	27	4222 062 95140	stand lower part
3	4222 062 95230	reflector facial	28	4222 062 95490	bearing bracket (set)
4	4222 062 95260	fan complete	29	4222 062 95340	memo panel
5	4822 325 20102	lamp holder	30	4222 062 95050	remote control
6	4822 134 30032	HPA flexpower 400-600	31	4222 062 95320	flex holder
7	4222 062 95240	reflector standard	32	4222 062 95310	cover floorpart L
8	4222 062 95360	housing rad. part L	33	4222 062 94720	power module
9	4822 214 12662	14-tabs pcb	34	see item 9	
10	4822 410 40417	switch pin	35	4822 528 11215	wheel large
11	4822 404 40639	switch bracket	36	see item 12	
12	4822 271 30619	micro switch	37	4822 265 20234	connecting block mains
13	4822 690 80147	HB 072 protecting goggles	38	4222 062 94860	4-s connector mains
14	4222 062 95370	cover rad. part L	39	4222 062 94870	4-s connector capacitors
15	4222 062 95280	hinge parts (set)	40	4222 062 94850	9-s connector ballasts
16	4222 062 95390	cover rad. part R	41	4222 062 94730	fan complete
17	4222 062 95150	gas spring	42	4822 321 11395	mains flex
18	4222 062 95020	distance indicator	43	4222 062 95300	orn. prop (set)
19	4222 062 95160	cover gas spring	44	4222 062 95290	cover floor part R
20	4222 062 95110	switch plate	45	4222 062 94330	ballast 400 W / 230 V
21	4222 062 95380	housing rad. part R	46	4222 062 94740	bar grip
22	4222 062 95350	stand upper part	47	4222 062 95330	housing floor part
23	4222 062 95170	orn. strip (set)	48	4222 062 95120	clamp
24	4822 530 70444	spring fix	49	4822 528 70519	wheel small
25	4222 062 95180	orn. cap (set)	50	4222 062 94890	ballast 100 W / 230 V
			51	4222 062 94600	capacitor 50 µF / 250 V

# HB 953/A

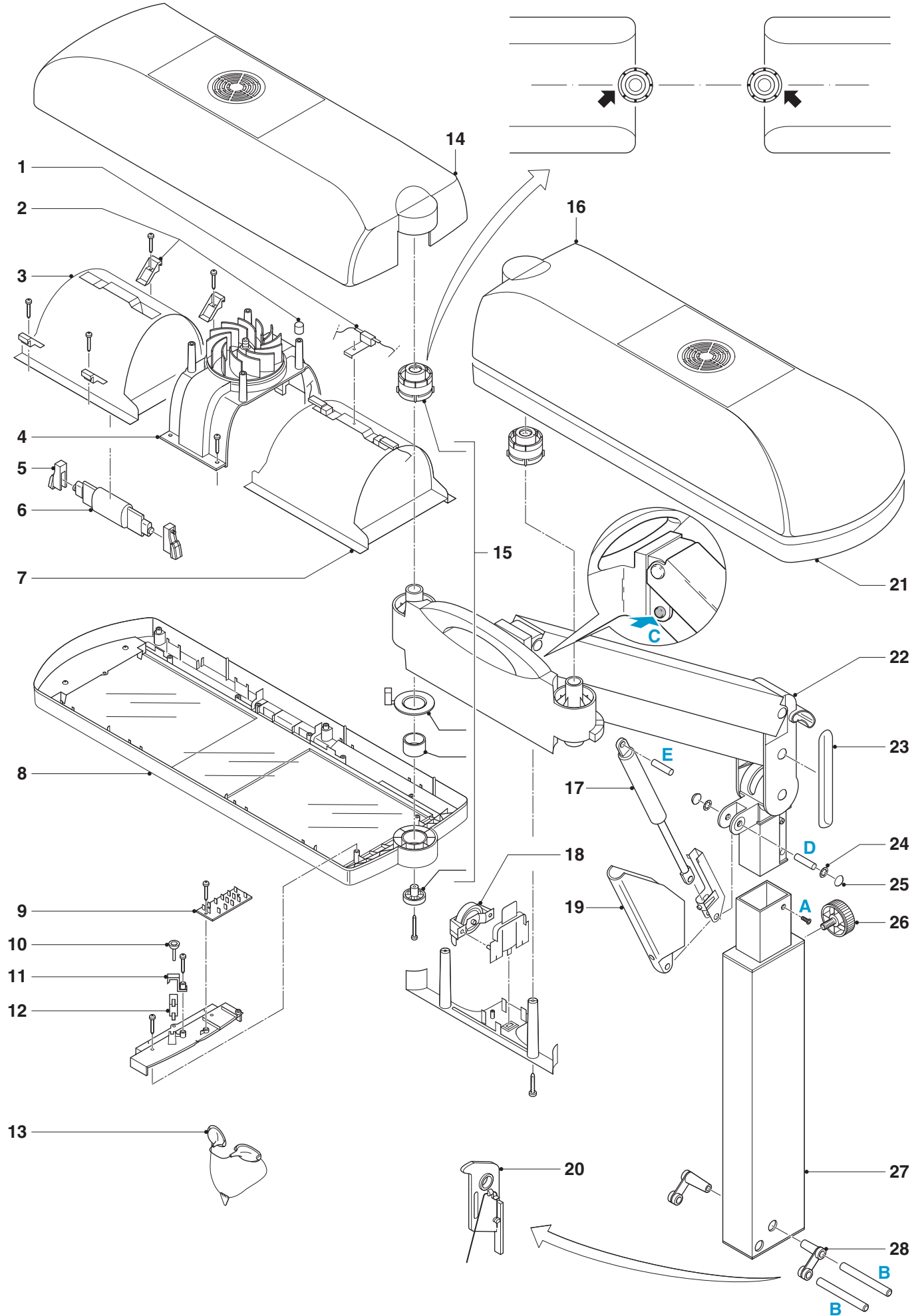

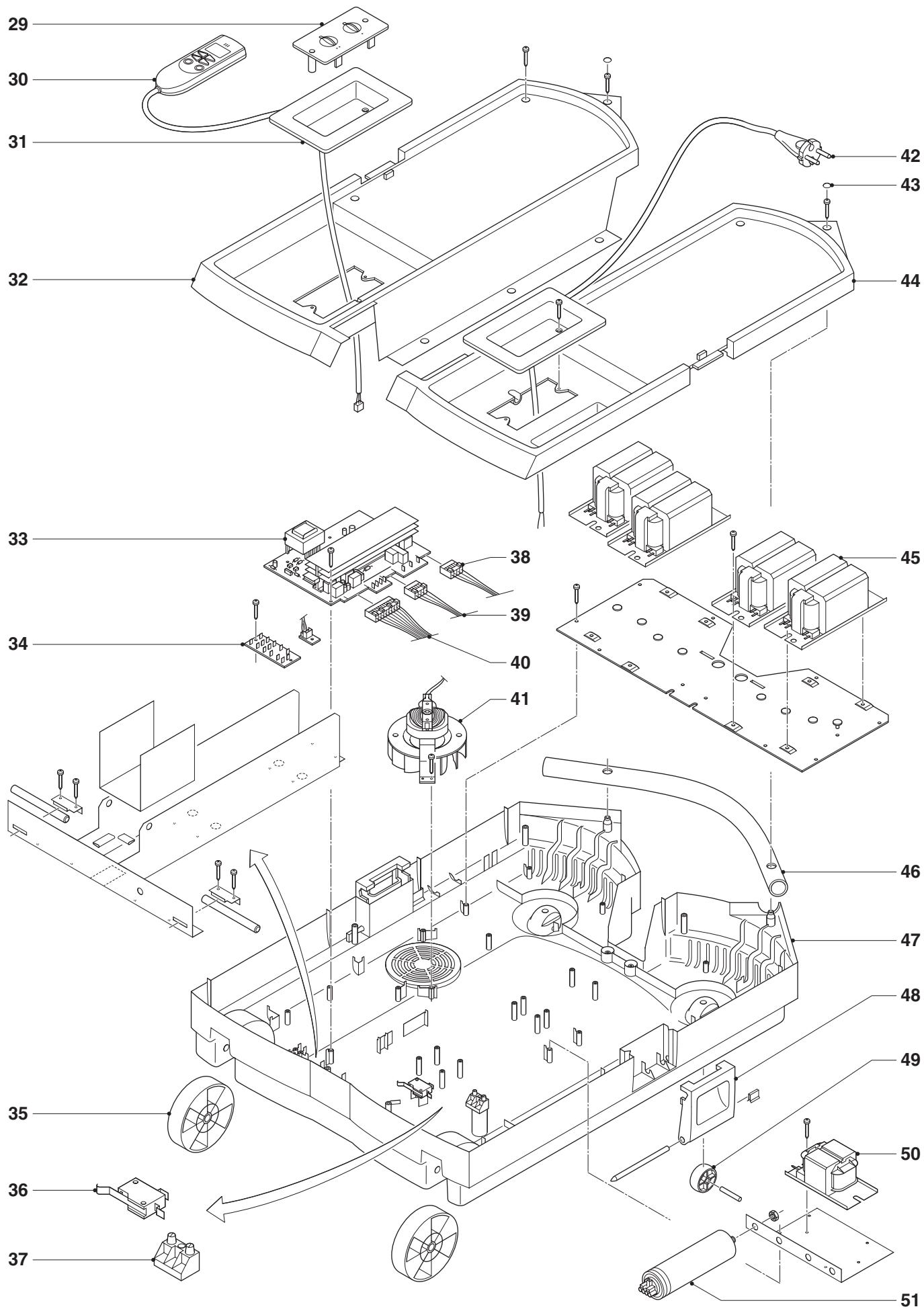

# HB 953/A

